



Pilous

Železná 9, 619 00 Brno, Czech Republic

Tel.: +420 543 25 20 10

e-mail: wood@pilous.cz, www.pilous.cz

CTR 800



4920 x 35-40 x 0,9-1,1 mm



Max. log diameter	830 mm
Max. opening between blade guides	750 mm
Max. elevation of blade	685 mm
Min. log height	30 mm
Max. depth of cut	450 mm
Max. log length (standard model)	1,8 m
Length track section	3 m
Min. log length	1 m
Saw blade motor	7,5 (11) kW
Horizontal feed motor	0,55 kW
Vertical feed motor	0,55 kW
Sawblade	4380 x 35÷40 x 0,9÷1,1 mm
Weight (standard model)	750 kg
Weight (track section)	131 kg

Nominal current of circuit breaker is minimally 32 / 40 Ampere

Feed to the cut and back – motor-powered
Arm height adjustment – motor-powered
Control panel – on a mobile bridge
Log handling – manual (hydraulic)

Innovative version of the extremely successful CTR 800 that has been on market for 15 years now.

The key change lies in the increase of the impeller diameter from the original 500 mm to 600 mm. This allows you now to use 1.3 mm thick saw blades in contrast to the formerly used 0.9 – 1,1 mm blades. Using a 1.3 mm thick saw blade is the newest trend in band saws with narrow blades. The risk of blade rippling in the cut even at high speeds is substantially reduced. Thus, the machine productivity and the cutting accuracy are considerably increased.

Apart from the new machine design, there are many technological adjustments that improve user comfort as well as the quality and durability of the machine.

The design of the arm (now 40 kg heavier) and the sliding hard chromium rods has been reinforced. Due to heavier weight, the motor is now equipped with a brake, as in machines of the highest category. It significantly increases the accuracy of stopping at the desired point and contributes to the service life of the whole uplift system. Universal log band saw which is, with its maximum cutting diameter of 83cm, suitable for most lumber.

A wide, exceptionally massive running bridge of the band saw arm and robust running sections ensure undisturbed operation when cutting and even at high running speeds. Professional execution of all main technical units, such as running wheels with their bearing system, saw band arm construction, powering and feeding system, etc. ensure maximum service life and machine accuracy even under the most difficult operating conditions.

Continuously adjustable machine feed to the cut and back and band saw arm height adjustment. Travel speed is displayed on the digital display. In this version of the machine, the control panel is placed on a mobile bridge of the band saw arm. Thanks to that the operator has closer access to the workpiece when cutting.

The feed to the cut and back is driven by an electric motor with worm gearbox controlled by a frequency converter. You can change the speed of travel simply by turning the potentiometer on the control panel. End positions are secured against impact by means of limit switches with automatic deceleration and stopping.

The massive band saw arm is borne on adjustable hard-chromium rods (for moving up and down) which ensure absolute accuracy of band saw arm movement and virtually unlimited service life, if the machine is lubricated regularly. The vertical movement of the arm is provided by double-sided synchronous chain transmission powered by an electric motor with worm gearbox. The movement controlled from the central panel has two modes of speed – rapid feed and slow feed for accurate movement to a desired position. This system can be always additionally equipped with electronic metering which automatically moves to the specified position.

The arm is fitted with blade wheels made of high-quality grey cast iron with accurate balancing against vibrations. The wheel has a groove along its circumference. The groove holds a replaceable rubber-textile belt which creates an optimum contact area between the wheel and the saw blade. The sturdily mounted blade wheel is powered through a wedge belt by a professional electrical motor specially balanced against vibrations.

The tensioning wheel system moves along a sturdy cast iron wedge guide with adjustable pressure bar, which allows highly accurate adjustment without any play even in long-term machine operation.

The saw blade is guided in the cut by hardened and ground guide pulleys. This system can be fully adjusted in all directions and it ensures optimum position of guide pulleys and the saw band.

In order to ensure accuracy of the cut the guide pulley on the operator's side moves as close as possible to the workpiece. Simply operated massive bearing system. It can be motor-powered and controlled as an auxiliary device from the control panel.

Stable running sections with steel arm bridge guides form the basis of the machine. They are sufficiently dimensioned for maximum diameters of logs as well. They were designed reflecting the practice, therefore designed to cope with very hard operating conditions. Cut length is virtually unlimited in all types of machines, it only depends on the length of running gear installed. Running gear sections are fitted with massive, height-adjustable log-bearing surfaces and adjustable retractable angles and log clamps.

The basic version of the machine includes 3 workpiece clamps and 2 angular steady bars.

Gravity cooling and lubricating of the band with adjustable outlets in both guide pulleys ensure that the saw band is in optimum condition during cutting.

CTR series present the latest trends in construction of log saw bands with a special emphasis on maximum accuracy and long-term service life of the machine while ensuring minimum costs.

The machines are designed in an original modular execution which allows easy replacement or adjustment of all main technical sections and their individual parts. This in the long-term perspective reduces the maintenance costs and service times and therefore production stoppages as well.

Accessories – there is a wide range of accessories to all of these machines; they simplify and accelerate machine operation and influence its production. Our original modular system allows additional installation of necessary equipment at any time, because all basic versions of machines include all fitting spots including holes and threads.

PHOTOGALLERY

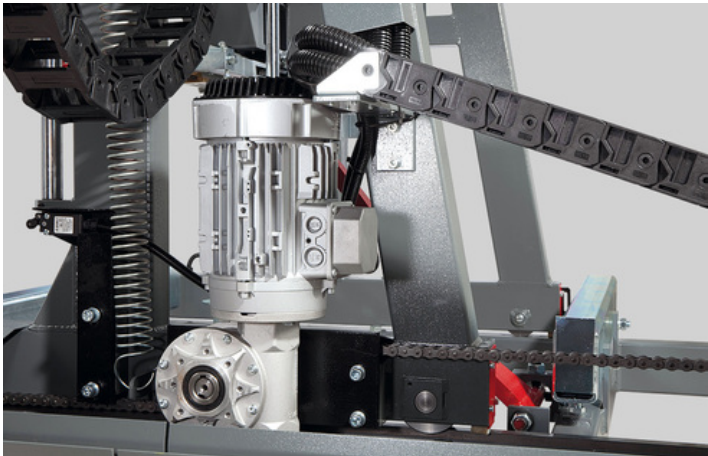
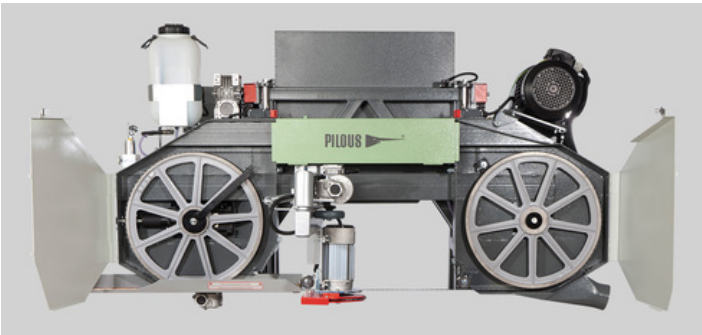
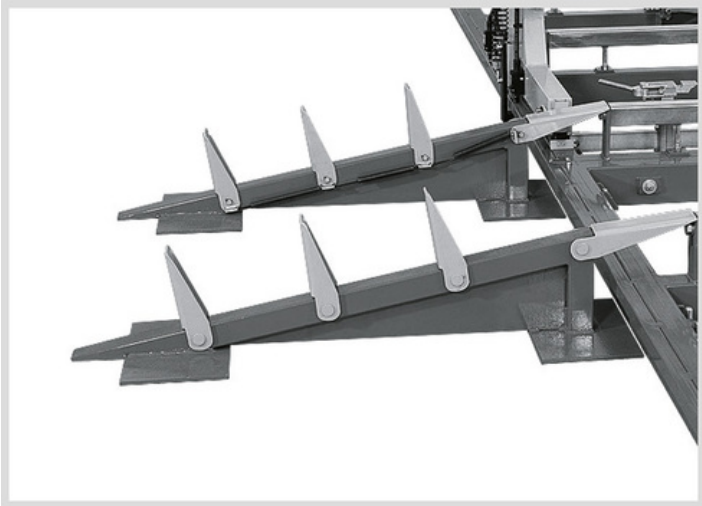

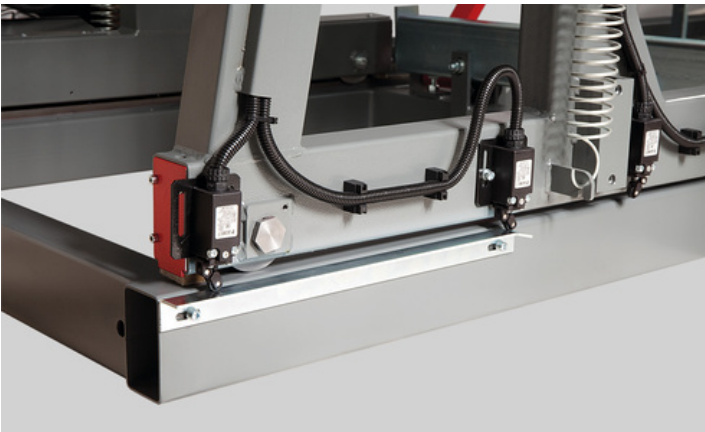
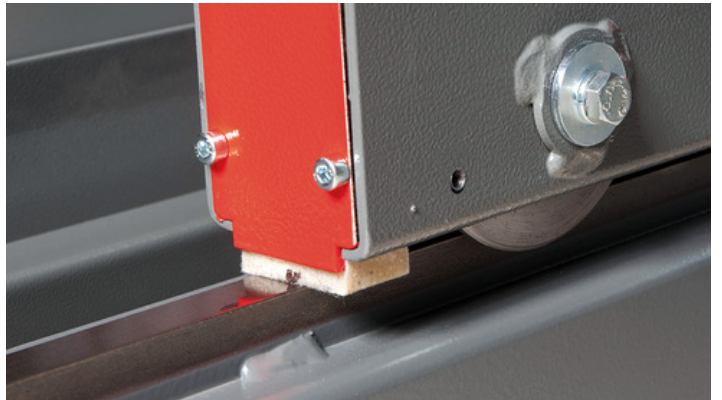
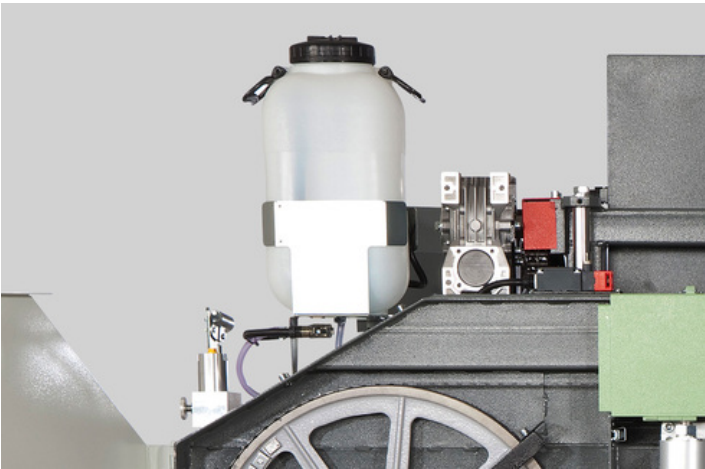
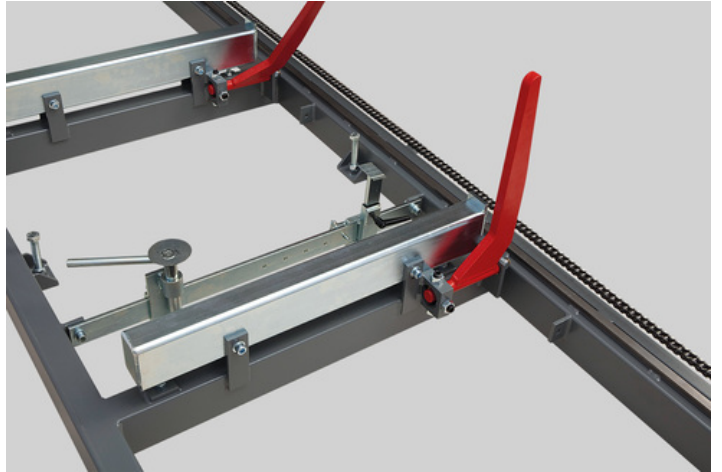
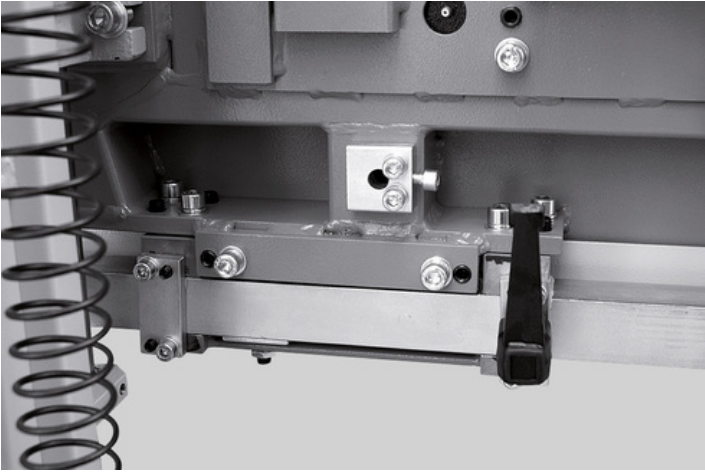
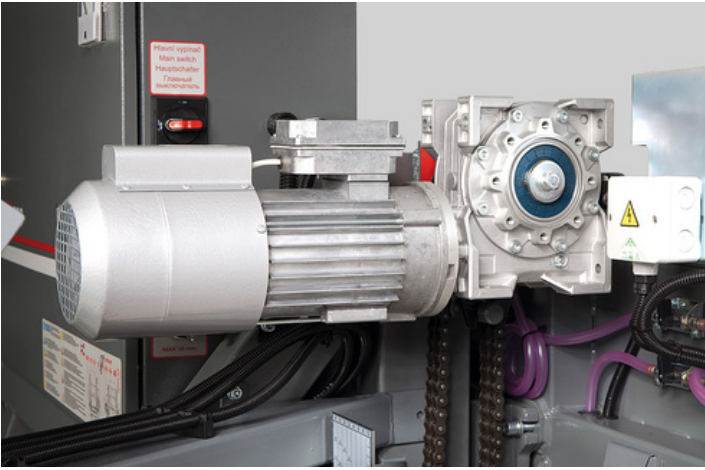

ACCESSORIES

ACCESSORIES – SPECIAL ACCESSORIES



Main motor 11 kW

Main motor 11 kW

Stronger output of motor provides faster cut, mainly with huge diameters of logs.



Track section 3 m

Track section

3 meter – contain in basic: 1x squaring arm
Extending section is equipped with many points for installation of hydraulic equipment. That provides variability of placement with aspect of cutting material.



LG 100

LG 100

It is intended for a quick and accurate setting of required board thickness. The movement of the band saw arm up and down is displayed with an accuracy of 0.1 mm on a colour display. The absolute height from the band saw bed or, after reset, the set board thickness including the optional kerf thickness is displayed.



LG Automat

LG automat

Digital measuring system for fast and accurate automatic setting of the desired thickness of the cut. After the specification of basic settings (height from the loading area and cut-through) and of the desired value (cut thickness), the arm with a saw band will automatically move to the required position. That prevents human-induced failures that can arise during manual cut settings. Saves time, refines production.



Pre-cutter / 800

Pre-cutter

The pre-cutter circular with hard metal tips is designed to remove dirt at points where the saw blade cuts into the log. The saw blade do not get blunt quickly. Frequent saw blade exchanges are reduced, the saw blade life, and the productivity of the machine increase.

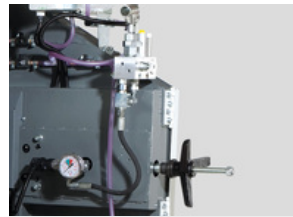

Hydraulic saw blade straining / 800

Hydraulic saw blade straining

Operated by a hydraulic hand pump with accurate pressure indication. The saw blade straining is more accurate and convenient.



Ammeter

Ammeter

The ammeter scale shows the saw blade engine load during the cut. It is designed to simplify the selection of the feed speed; it also indicates the saw blade bluntness. A timely exchange of the saw blade increases the life-span and improves the cutting quality.



Soft starter

Soft starter

Electronic device enabling a smooth start-up of the band saw main motor. It prevents grid surges reducing mechanical stress of the whole machine. For motors 11 kW.



Electrically controlled bar / 800

Electrically controlled bar

Adjustment of sliding guide bar of the saw blade depending on the log diameter electrically controlled from the central control desk.



Lever for log loading

Lever for log loading

Serves as help with manipulation with logs on machine frame.



Hard-metal saw band guidance 710 / 800

Hard-metal saw band guidance
It is located on the moving rail before the cut. It significantly improves saw band stability in the cut and also in its cleaning. Therefore it increases the machine productivity and cutting accuracy. This machine can be installed on an electrically controlled rail.



Material Clamp

Material Clamp
Consists of a rail and a front and rear clamp.



Route for feeding logs

Route for feeding logs
Provides easy and safe manipulation on machine cross beams with system of flexible stops.

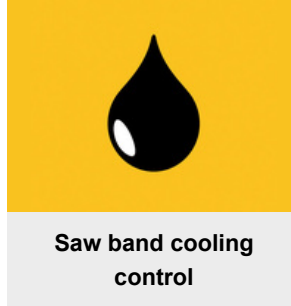

Saw band cooling control

Saw band cooling control
Integrated in the cooling system is an electromagnetic through-flow valve, which automatically opens when the saw blade is started and closes when the saw blade is stopped. It substantially lowers the coolant consumption and saves time needed for replenishment of coolant liquid.

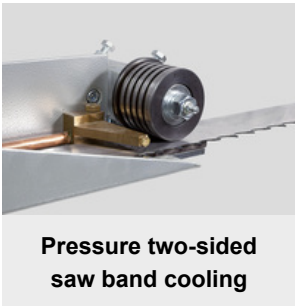

Pressure two-sided saw band cooling

Pressure two-sided saw band cooling
The cooling system consists of a pressure pump in the coolant tank, flow control solenoid valve and two-way jets that spray the saw band both from below and from above. Two-side cooling prevents undesirable stress in the saw band and adhesion of resin from underneath the saw band and thus helps maintain stabler saw band operation, more accurate cut and longer service life.



ARCTIC version

ARCTIC version
Version of the machine adapted for work in extremely cold operating temperatures reaching down to -40°C . Machine's switch board, control panel and digital measuring (LG 100, LG Automat) are fitted with heating elements. The heating is controlled through a thermostat. Frost-resistant lubricant. Band saws CTR 800 H, 950 H, 1000 H and 1300 H use frost-resistant hydraulic oil.



LED lighting (11 W)

LED lighting (11 W)
Good quality lightening of the workspace using two powerful LED strips mounted on a movable bridge.

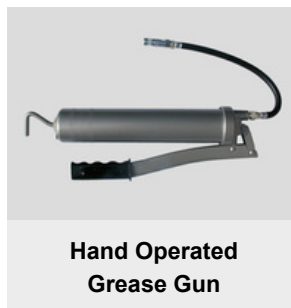

Hand Operated Grease Gun

Hand operated grease gun
For regular maintenance of the machine according to the lubrication plan. Metal grease gun for 400g cartridges. Equipped with a flexible pressure tube.



Grease LV 2-3

Grease LV 2-3
400g cartridge for the grease gun.

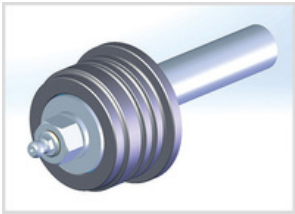

**Saw Band Guide
Pulley VK 35**

Saw band guide pulley VK 35
Hardened ground pulley, bearings,
shaft for a saw band 35 mm wide.

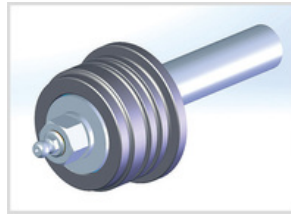

**Saw Band Guide
Pulley VK 40**

Saw band guide pulley VK 40
Hardened ground pulley, bearings,
shaft for a saw band 40 mm wide.

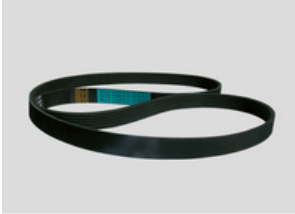

**Flat Running Wheel
Belt GPK 1885**

Flat running wheel belt GPK 1885

MAXWOOD

- The original saw blades PILOUS MAXwood are available in a variety of types which enables you to process any kind of wood.
- The wide product range not only offers more affordable saw blades for low-volume cutting, but includes also saw blades for fully professional cutting and utmost performance.
- The foundation of all saw blades are top-quality German materials and precise workmanship. The quality of the saw blades is carefully monitored. All saw blades correspond to the strict ISO 9001 norm.
- We have added to our portfolio also an original Munkfors saw blade made by the world's leading manufacturer Uddeholm from Sweden.
- Pilous saw blades are used in dozens of countries around the world. Any wood you cut, the company Pilous will recommend you a saw blade that will fit your needs.

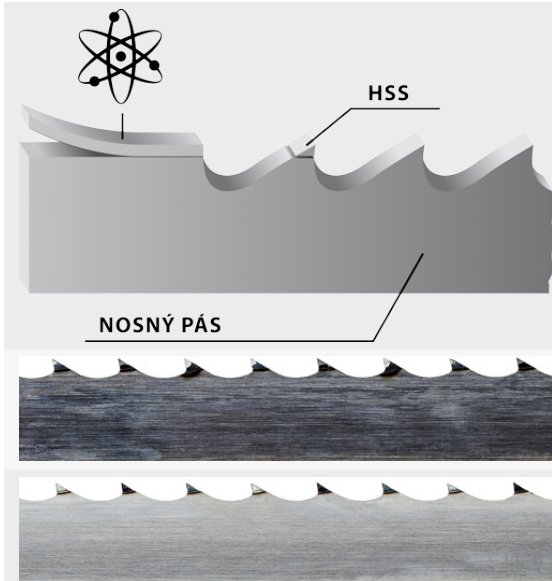

BiMetal

Saw blade with tool steel teeth - completely eliminates the need to sharpen the saw blade as well as frequent blade replacement. Use: soft, hard to extremely hard wood.

HSS

Bearing blade

Stellite

Saw blade with teeth made of Stellite. Tooth setting is completely unnecessary. Use: soft, hard to extremely hard wood.

Carbon spring steel

The most common saw blade for optimum price/performance ratio. Use: soft and hard wood.



Be careful when unpacking welded saw blades. They are in a shipping container in tensioned condition. Remove the saw blade cover only after fitting it onto the machine.

